

GENERAL NOTES

1. Brick, block, or concrete may be used.
2. T = 8" for brick structure
T = 6" for segmental block structure
- 3 In special cases or where inlet pipe is required, A₁, B₁, A₂, and B₂ shall be increased or decreased 1'-0", as directed.
- 4 2" dia. pipe drain from bottom of curb to inlet. Aggregate to be placed around inlet end of pipe.
- 5 3" dia. pipe to be kept open for drainage of subgrade or base until surface is placed.

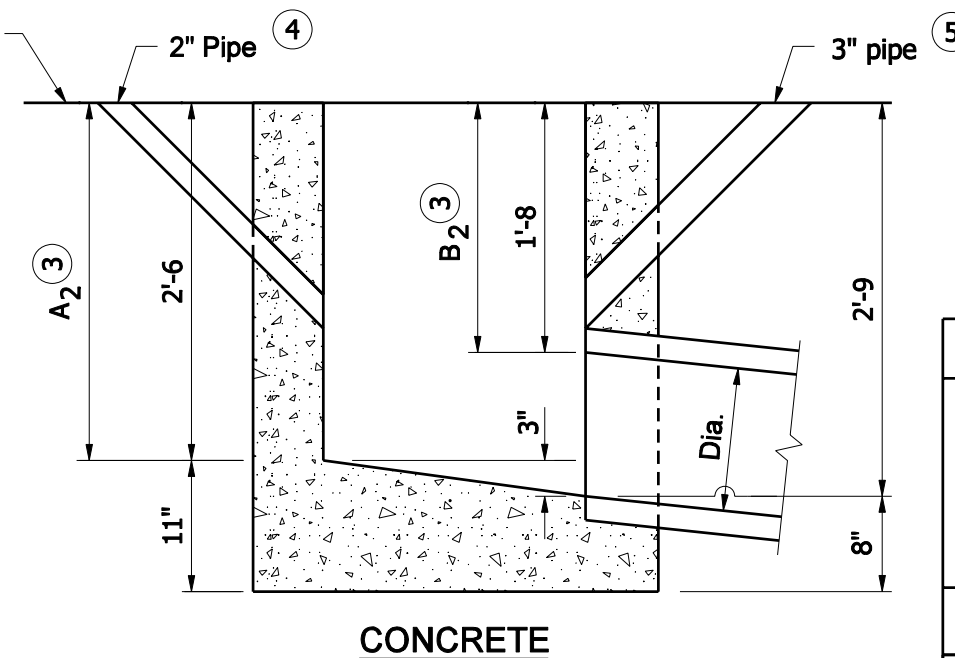
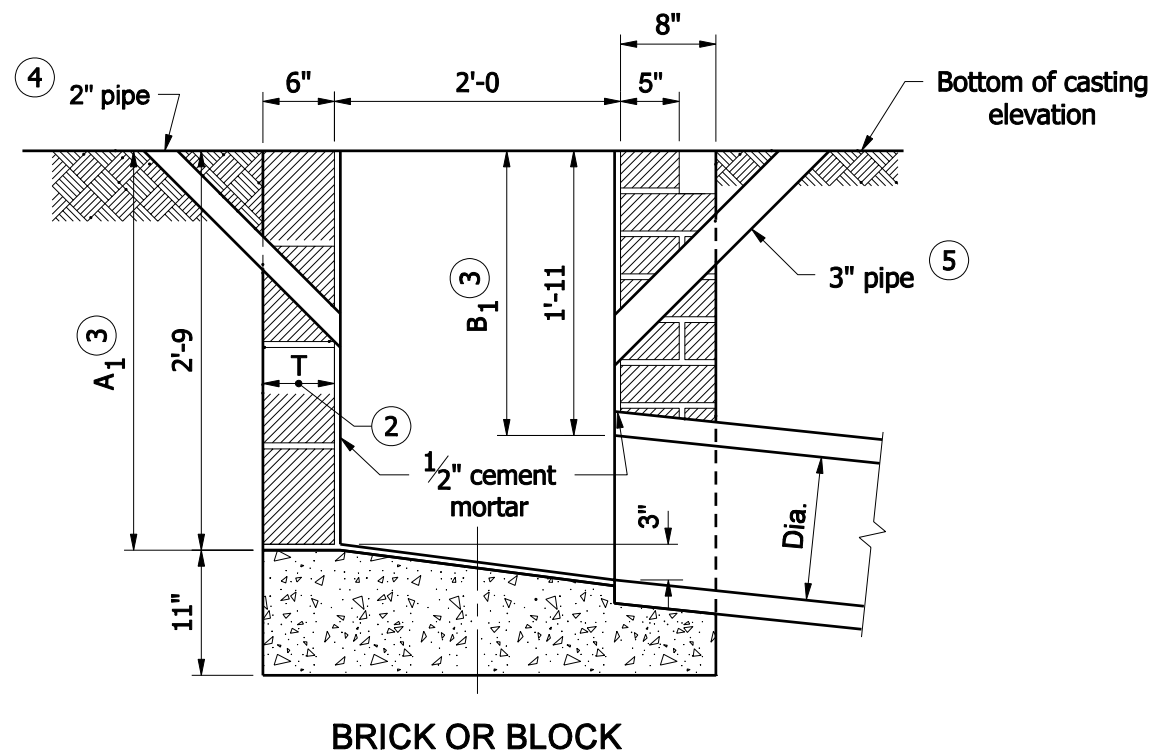
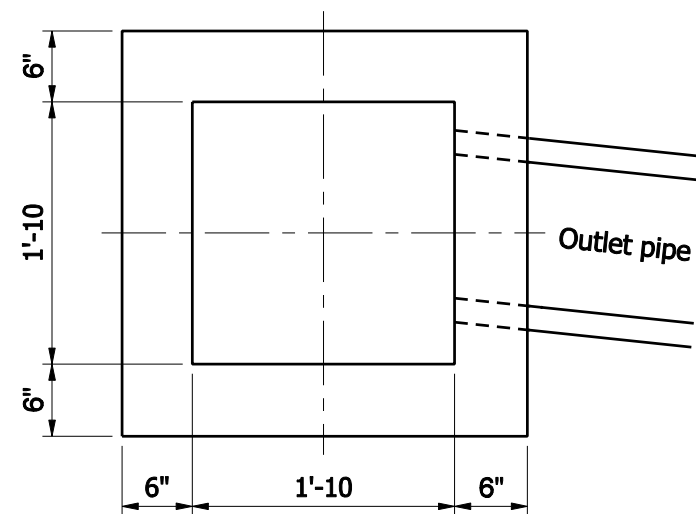
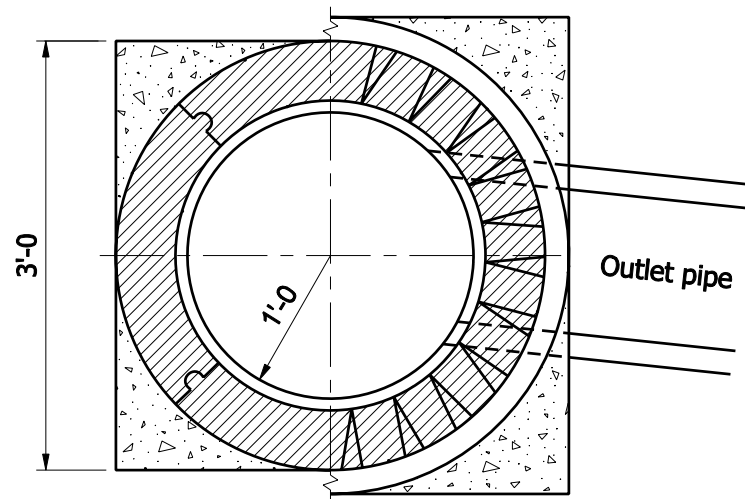

INDIANA DEPARTMENT OF TRANSPORTATION

INLET TYPE A

SEPTEMBER 2008

STANDARD DRAWING NO. E 720- INST-01

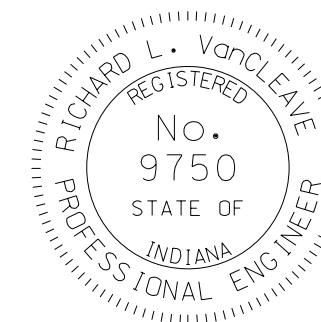

DESIGN STANDARDS ENGINEER

/s/ Richard L. VanCleave 09/02/08
DESIGN STANDARDS ENGINEER DATE

/s/ Mark A. Miller 09/02/08
CHIEF HIGHWAY ENGINEER DATE

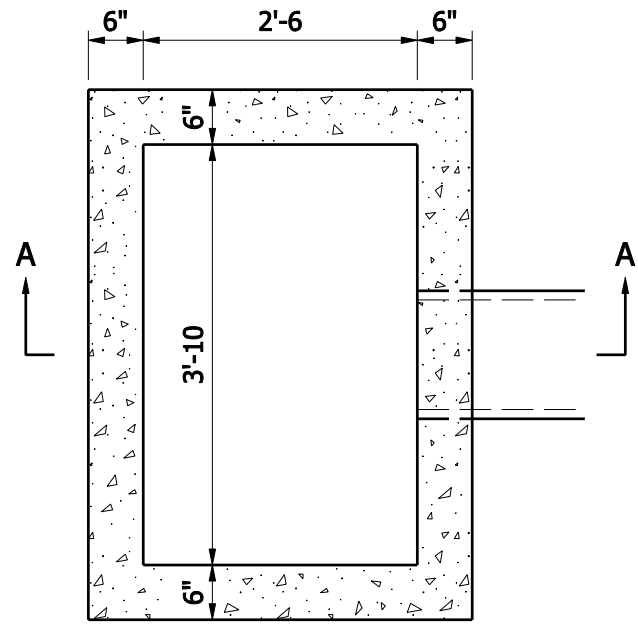

PLAN

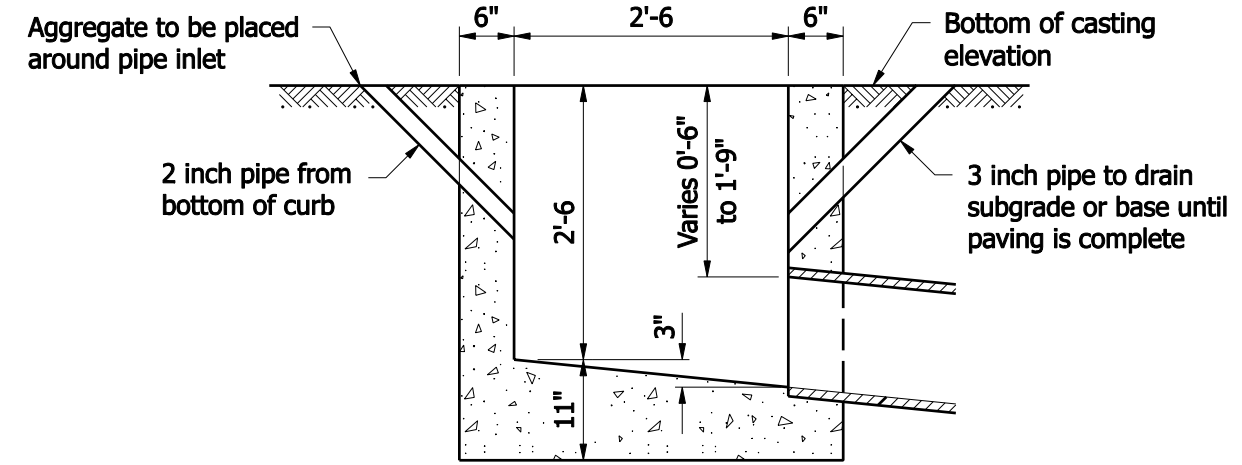

SECTION A-A

INLET-TYPE B

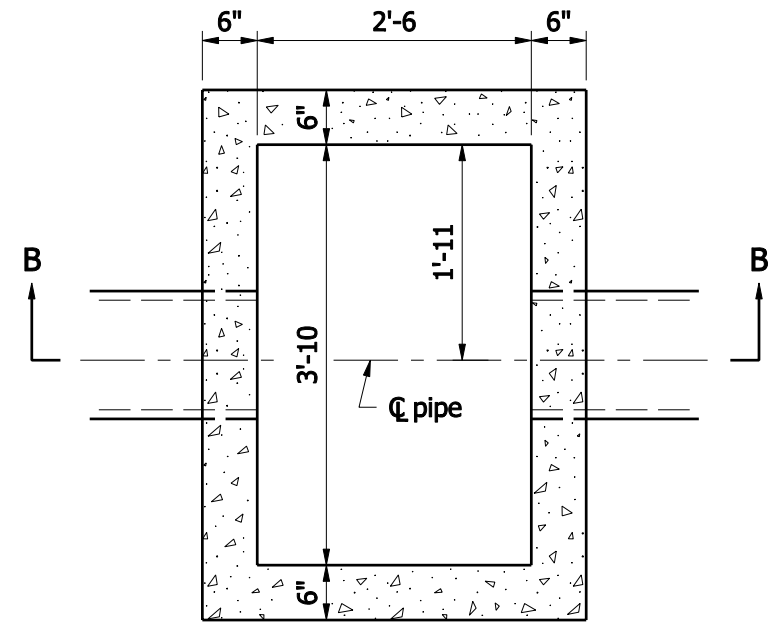

PLAN

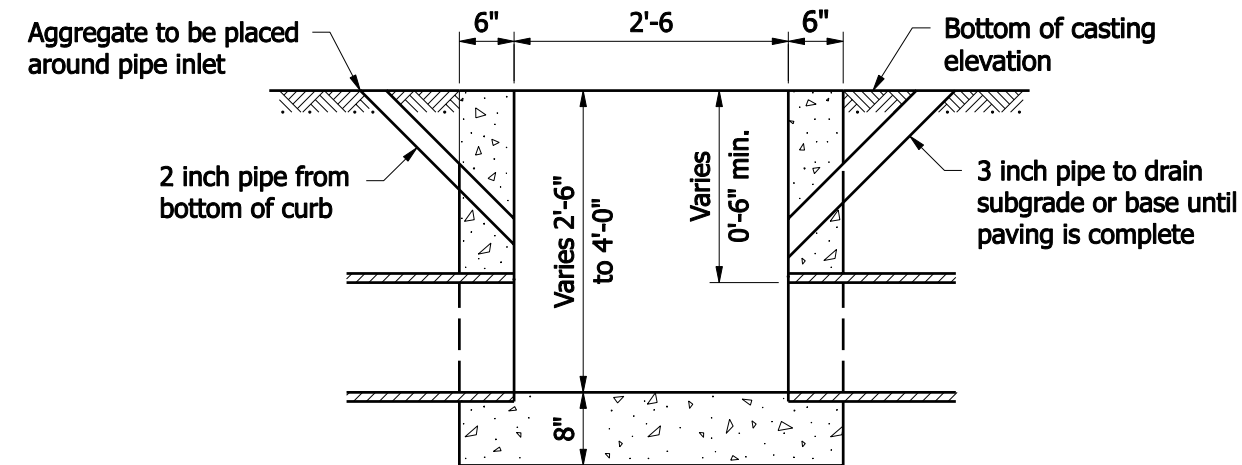

SECTION B-B

INLET-TYPE C

INDIANA DEPARTMENT OF TRANSPORTATION	
INLET TYPE B AND C	
SEPTEMBER 2008	
STANDARD DRAWING NO. E 720- INST-02	
	<p><i>/s/ Richard L. VanCleave</i> 09/02/08 DESIGN STANDARDS ENGINEER DATE</p> <p><i>/s/ Mark A. Miller</i> 09/02/08 CHIEF HIGHWAY ENGINEER DATE</p>
DESIGN STANDARDS ENGINEER	

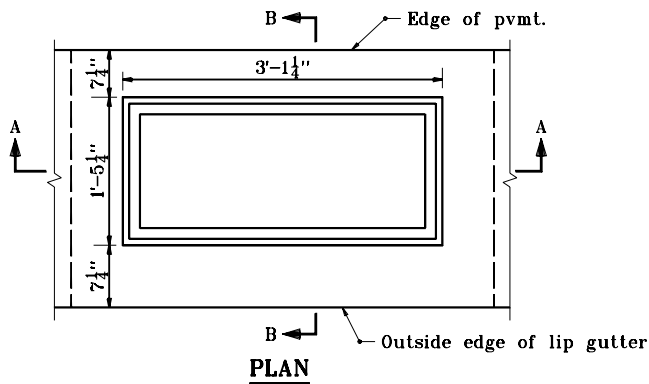

GENERAL NOTES

- 1 If inlet pipe is required, this dimension shall be increased or decreased 1'-0 as directed.

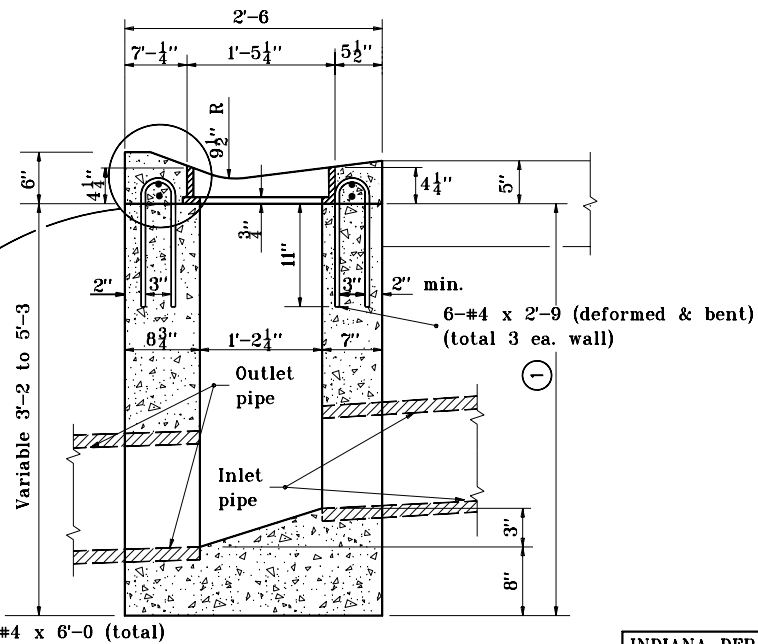
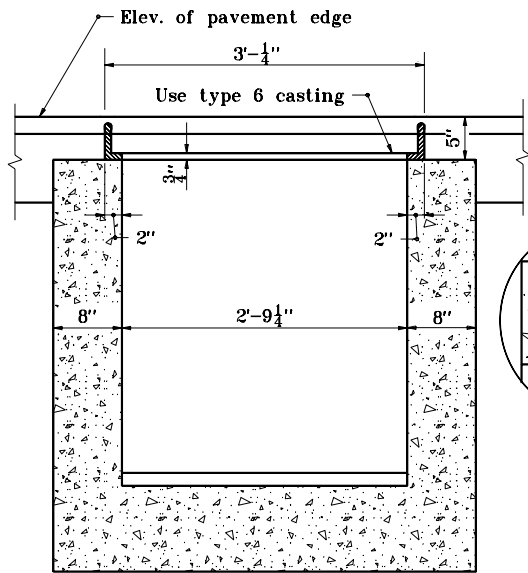

INDIANA DEPARTMENT OF TRANSPORTATION

INLET TYPE D

SEPTEMBER 1997

STANDARD DRAWING NO. E 720-INST-03

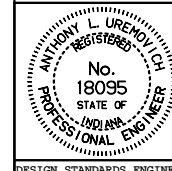

DETAILS PLACED IN THIS FORMAT 11-15-99

/s/ Anthony L. Uremovich 11-15-99
DESIGN STANDARDS ENGINEER DATE

/s/ Firooz Zandi 11-15-99
CHIEF HIGHWAY ENGINEER DATE

DESIGN STANDARDS ENGINEER

ORIGINALLY APPROVED 9-01-97

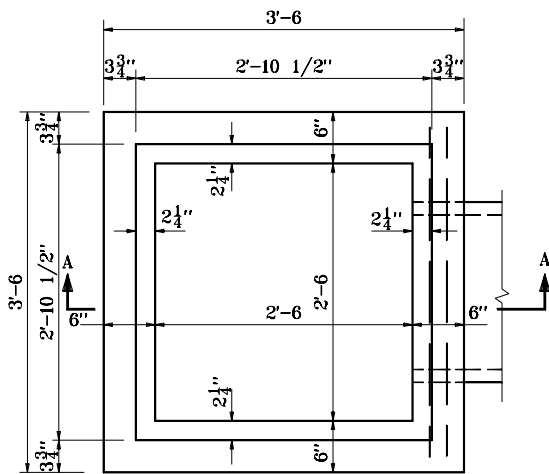

PLAN

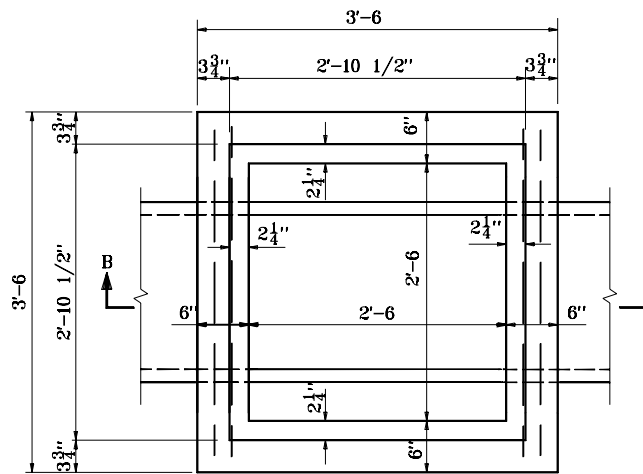

PLAN

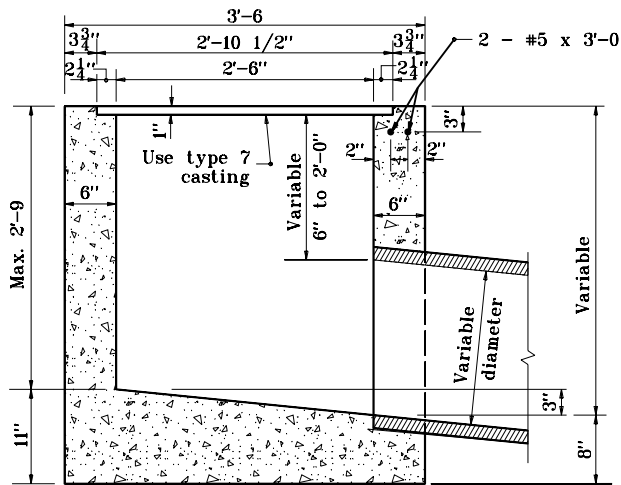

SECTION A-A

INLET TYPE E (CONC.)

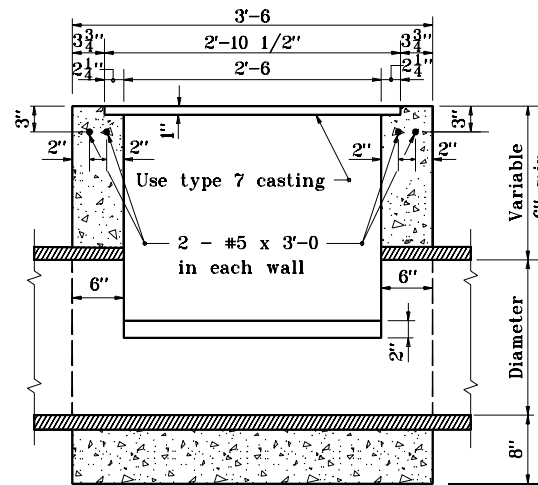

SECTION B-B

INLET TYPE F (CONC.)

INDIANA DEPARTMENT OF TRANSPORTATION	
INLETS TYPE E AND F	
SEPTEMBER 1997	
STANDARD DRAWING NO. E 720-INST-04	
DETAILS PLACED IN THIS FORMAT 11-15-99	
	/s/ Anthony L. Uremovich 11-15-99 DESIGN STANDARDS ENGINEER DATE
	/s/ Firooz Zandi 11-15-99 CHIEF HIGHWAY ENGINEER DATE
	ORIGINALLY APPROVED 9-02-97

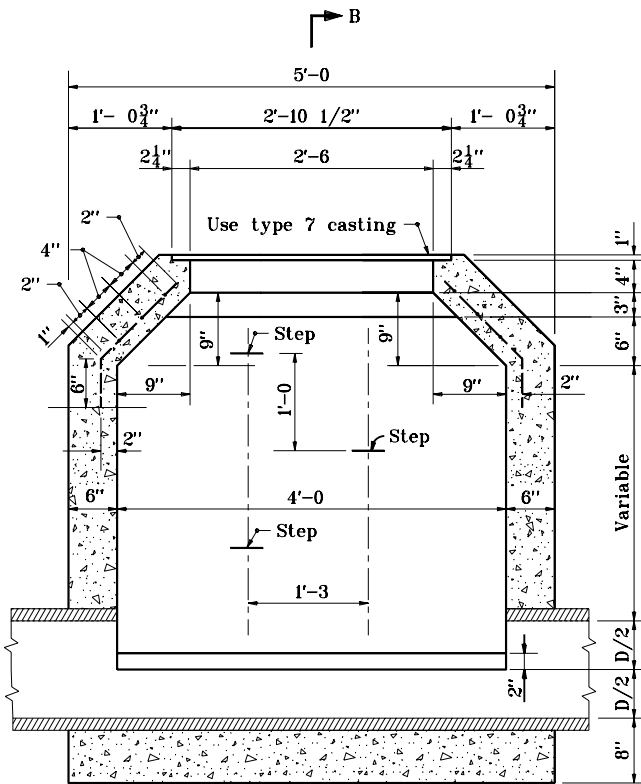

SECTION A-A

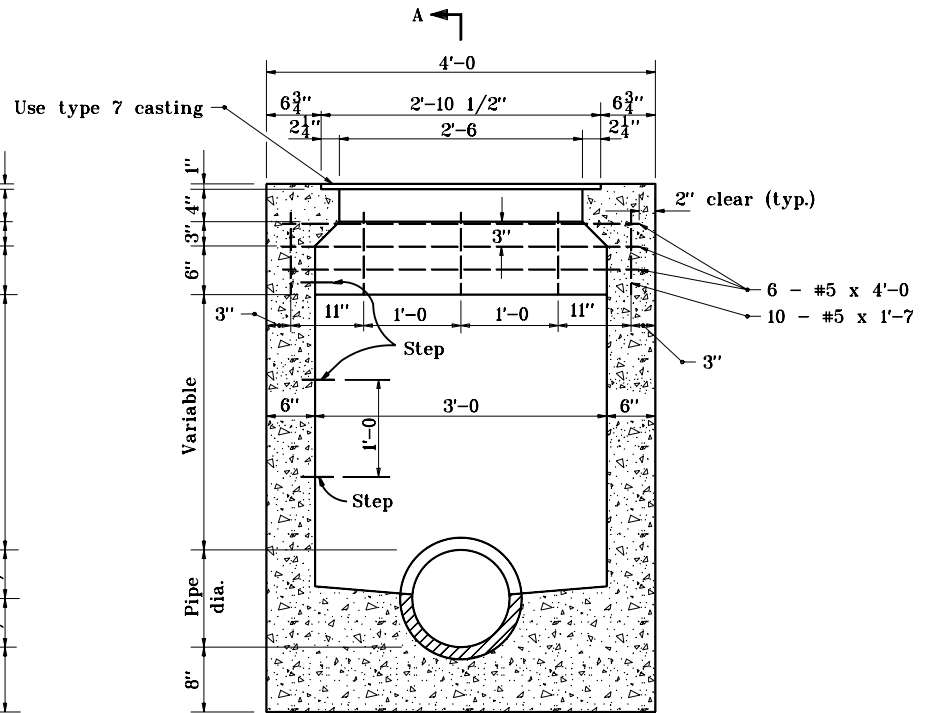

SECTION B-B

INDIANA DEPARTMENT OF TRANSPORTATION

INLET TYPE G

SEPTEMBER 1997

STANDARD DRAWING NO. E 720-INST-05

DETAILS PLACED IN THIS FORMAT 11-15-99

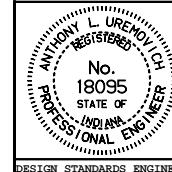

/s/ Anthony L. Uremovich 11-15-99
DESIGN STANDARDS ENGINEER DATE

/s/ Firooz Zandi 11-15-99
CHIEF HIGHWAY ENGINEER DATE

DESIGN STANDARDS ENGINEER

ORIGINALLY APPROVED 9-01-97

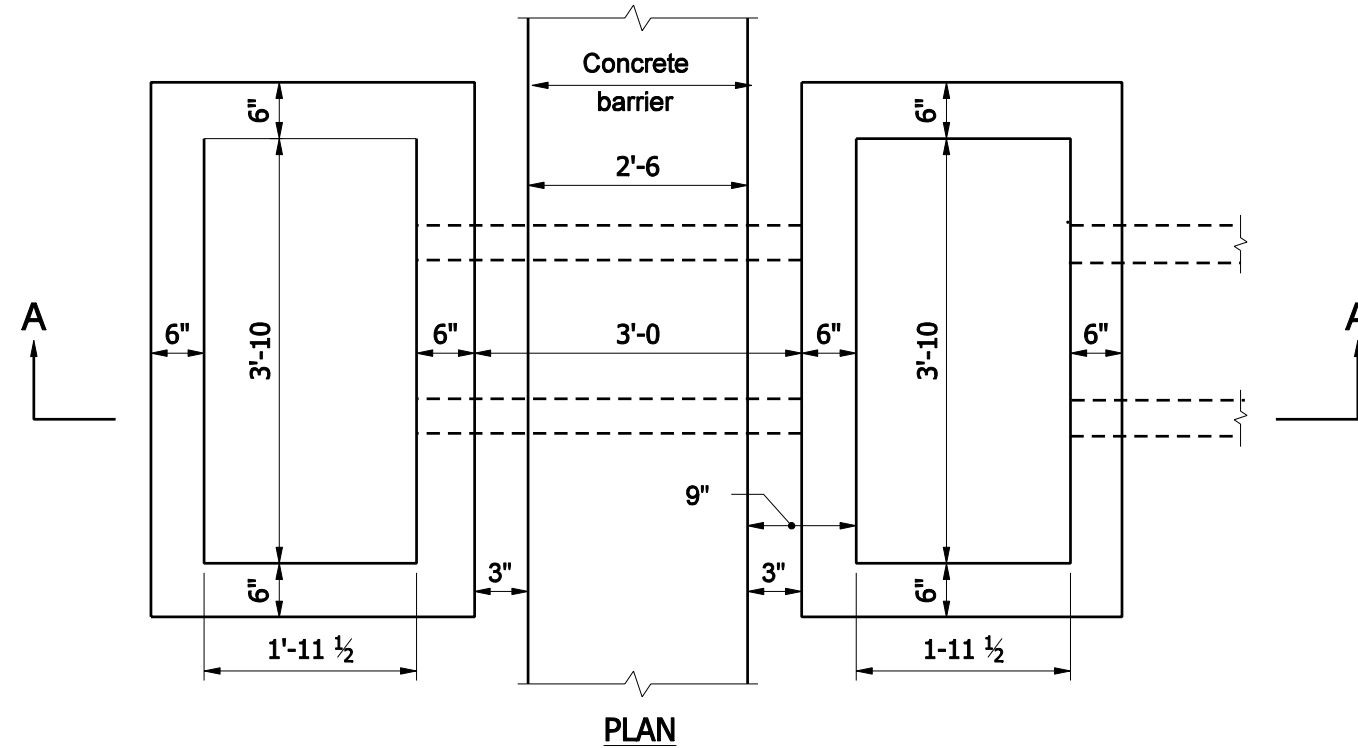

NOTES

1. Each inlet Type H includes two boxes and the connector pipe between the inlet boxes.
- ② See Standard Drawing E 720-ICCA-01 thru -03 for casting type 5 details.

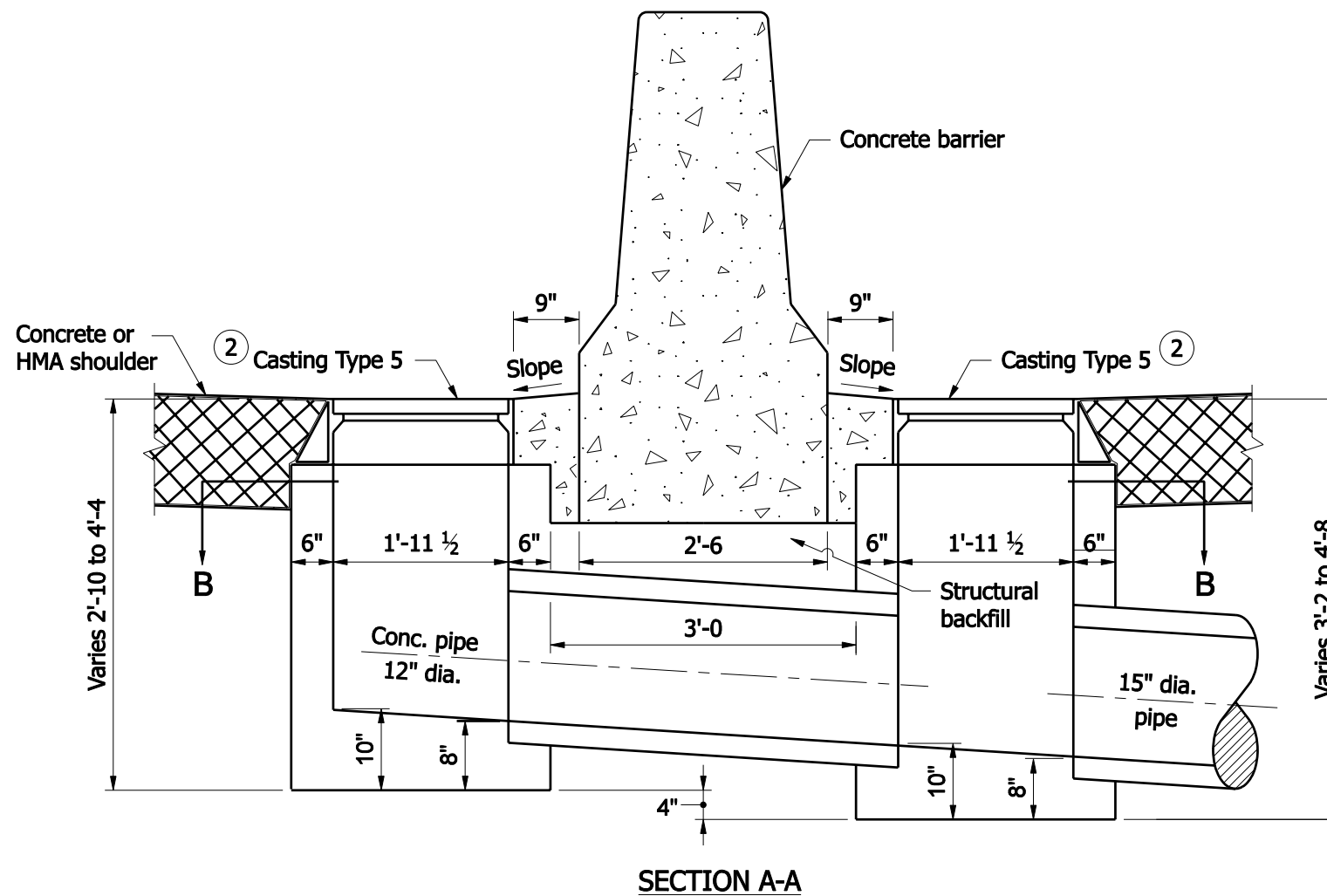

INDIANA DEPARTMENT OF TRANSPORTATION	
INLET TYPE H	
SEPTEMBER 2008	
STANDARD DRAWING NO. E 720- INST-05A	
	<p><i>/s/ Richard L. VanCleave</i> 09/02/08 DESIGN STANDARDS ENGINEER DATE</p> <p><i>/s/ Mark A. Miller</i> 09/02/08 CHIEF HIGHWAY ENGINEER DATE</p>
DESIGN STANDARDS ENGINEER	

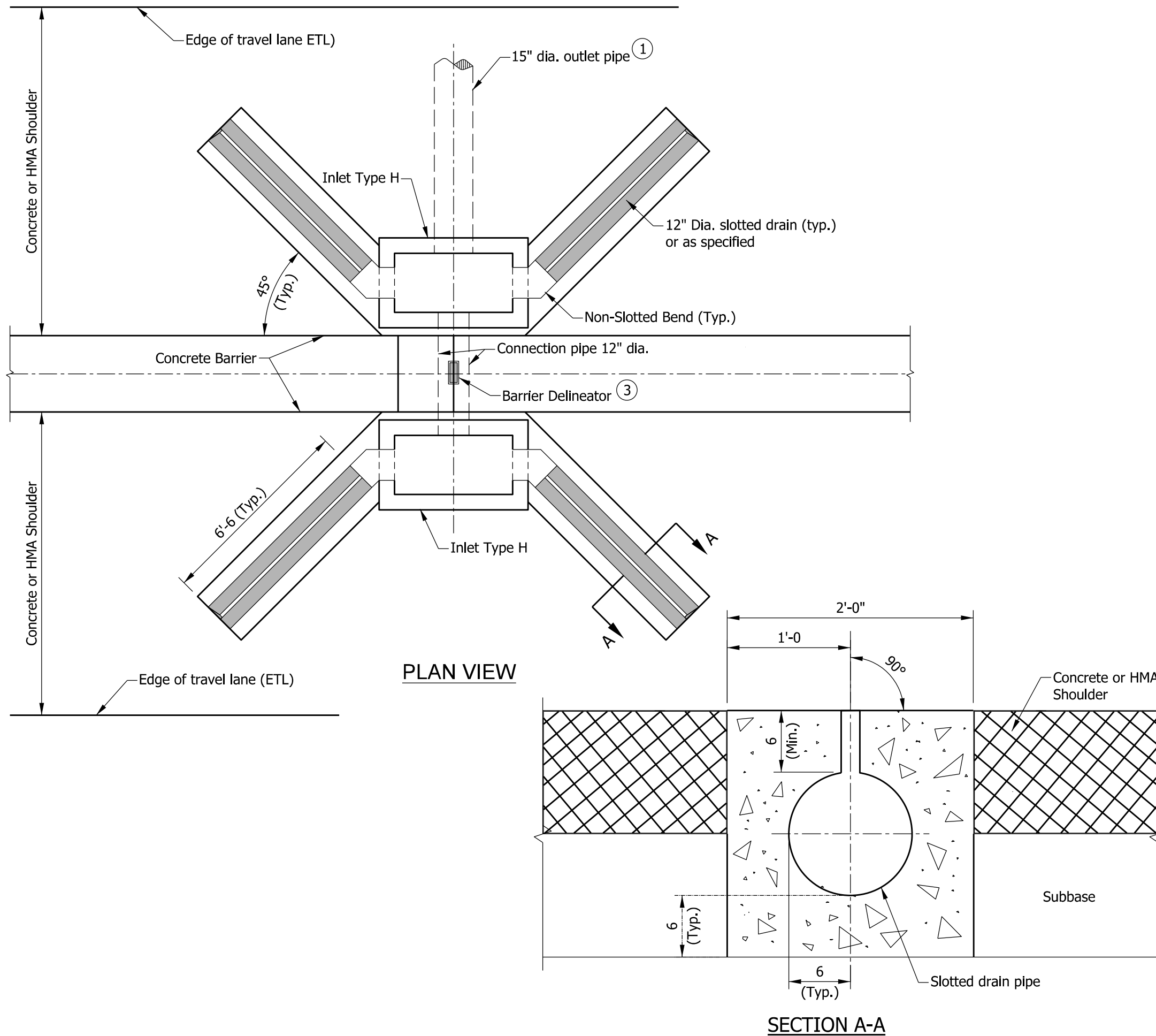

NOTES:

- ① Inlet and outlet pipe orientation to meet site conditions.
- 2. See Standard Drawing E 720-INST-05A for inlet Type H placement and details.
- ③ Barrier delineators provided to indicate the location of the inlets and shall be centered on top of concrete barrier at the inlets.

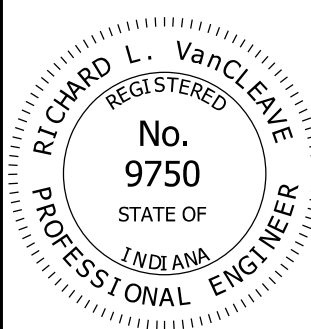
INDIANA DEPARTMENT OF TRANSPORTATION									
INLET TYPE H WITH SLOTTED DRAIN PIPE									
MARCH 2003									
STANDARD DRAWING NO.	E 720-INST-05B								
	<table style="width: 100%; border: none;"> <tr> <td style="border: none; padding: 2px;">/s/ <i>Richard L. VanCleave</i></td> <td style="border: none; padding: 2px;">03/03/03</td> </tr> <tr> <td style="border: none; padding: 2px;">DESIGN STANDARDS ENGINEER</td> <td style="border: none; padding: 2px;">DATE</td> </tr> <tr> <td style="border: none; padding: 2px;">/s/ <i>Richard Smutzer</i></td> <td style="border: none; padding: 2px;">03/03/03</td> </tr> <tr> <td style="border: none; padding: 2px;">CHIEF ENGINEER</td> <td style="border: none; padding: 2px;">DATE</td> </tr> </table>	/s/ <i>Richard L. VanCleave</i>	03/03/03	DESIGN STANDARDS ENGINEER	DATE	/s/ <i>Richard Smutzer</i>	03/03/03	CHIEF ENGINEER	DATE
/s/ <i>Richard L. VanCleave</i>	03/03/03								
DESIGN STANDARDS ENGINEER	DATE								
/s/ <i>Richard Smutzer</i>	03/03/03								
CHIEF ENGINEER	DATE								

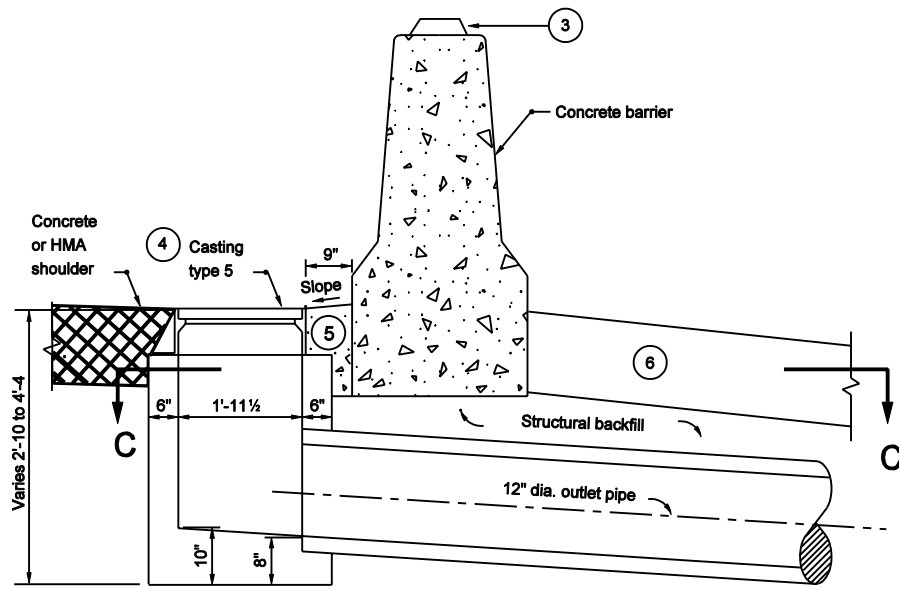

SECTION B-B

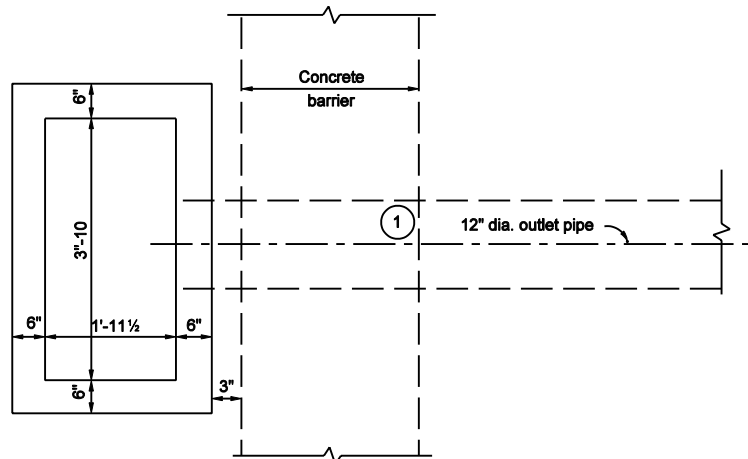

SECTION C-C

NOTES :

- ① Outlet pipe orientation to meet site conditions.
- ② See Standard Drawing E 720-INST-05D for Type HA inlet with slotted drain pipe placement.
- ③ All barrier delineator assemblies shall be centered on top of concrete barrier at the inlets.
- ④ See Standard Drawing E 720-ICCA-01 to -03 for casting type 5 details.
- ⑤ Concrete shoulder or pavement between type 5 casting and concrete barrier wall.
- ⑥ Concrete, HMA or earth shoulder as appropriate at site.

INDIANA DEPARTMENT OF TRANSPORTATION											
INLET TYPE HA SECTION B-B MARCH 2003											
STANDARD DRAWING NO. E 720-INST-05C											
	<table style="width: 100%; border: none;"> <tr> <td style="border: none;">/s/ Richard L. VanCleave</td> <td style="border: none; text-align: right;">3-03-03</td> </tr> <tr> <td style="border: none;">DESIGN STANDARDS ENGINEER</td> <td style="border: none; text-align: right;">DATE</td> </tr> <tr> <td colspan="2" style="border: none;"> </td> </tr> <tr> <td style="border: none;">/s/ Richard K. Smutzer</td> <td style="border: none; text-align: right;">3-03-03</td> </tr> <tr> <td style="border: none;">CHIEF HIGHWAY ENGINEER</td> <td style="border: none; text-align: right;">DATE</td> </tr> </table>	/s/ Richard L. VanCleave	3-03-03	DESIGN STANDARDS ENGINEER	DATE			/s/ Richard K. Smutzer	3-03-03	CHIEF HIGHWAY ENGINEER	DATE
/s/ Richard L. VanCleave	3-03-03										
DESIGN STANDARDS ENGINEER	DATE										
/s/ Richard K. Smutzer	3-03-03										
CHIEF HIGHWAY ENGINEER	DATE										
DESIGN STANDARDS ENGINEER											

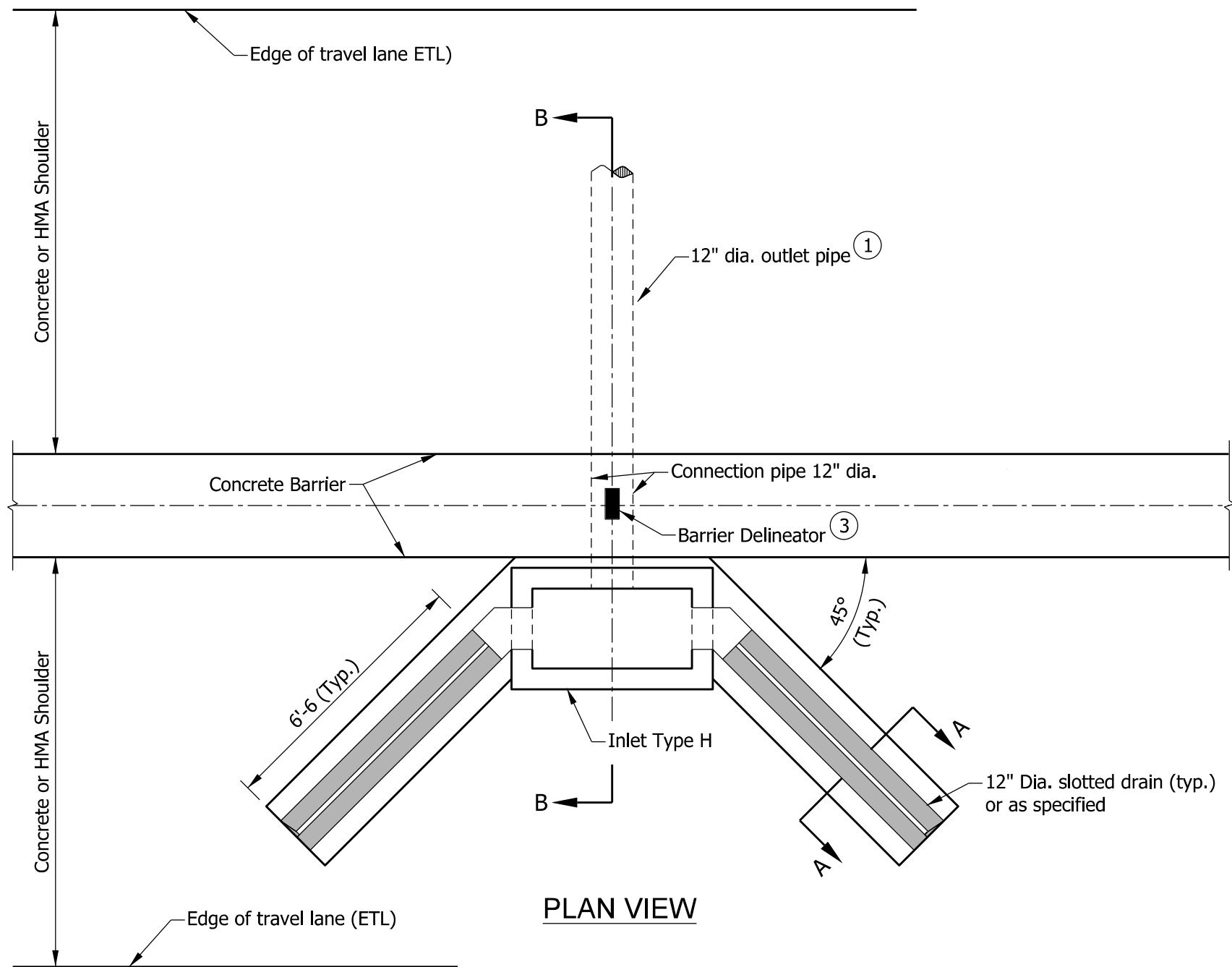

NOTES:

- ① Inlet and outlet pipe orientation to meet site conditions.
- 2. See Standard Drawing E 720-INST-05B for section A-A.
- ③ All barrier delineators assemblies shall be centered on top of concrete barrier at the inlets.
- 4. See Standard Drawing E 720-INST-05C for section B-B.

INDIANA DEPARTMENT OF TRANSPORTATION									
INLET TYPE HA WITH SLOTTED DRAIN PIPE									
MARCH 2003									
STANDARD DRAWING NO.	E 720-INST-05D								
	<table style="width: 100%; border-collapse: collapse;"> <tr> <td style="border-bottom: 1px solid black; padding: 2px;"><i>/s/ Richard L. VanCleave</i></td> <td style="border-bottom: 1px solid black; padding: 2px;">03/03/03</td> </tr> <tr> <td style="padding: 2px;">DESIGN STANDARDS ENGINEER</td> <td style="padding: 2px;">DATE</td> </tr> <tr> <td style="border-bottom: 1px solid black; padding: 2px;"><i>/s/ Richard Smutzer</i></td> <td style="border-bottom: 1px solid black; padding: 2px;">03/03/03</td> </tr> <tr> <td style="padding: 2px;">CHIEF ENGINEER</td> <td style="padding: 2px;">DATE</td> </tr> </table>	<i>/s/ Richard L. VanCleave</i>	03/03/03	DESIGN STANDARDS ENGINEER	DATE	<i>/s/ Richard Smutzer</i>	03/03/03	CHIEF ENGINEER	DATE
<i>/s/ Richard L. VanCleave</i>	03/03/03								
DESIGN STANDARDS ENGINEER	DATE								
<i>/s/ Richard Smutzer</i>	03/03/03								
CHIEF ENGINEER	DATE								

GENERAL NOTES

1. Brick, block, or concrete may be used.
2. T = 8" for brick structure
T = 6" for segmental block structure
- 3 In special cases or where inlet pipe is required, A₁, B₁, A₂, and B₂ shall be increased or decreased 1'-0", as directed.
- 4 2" dia. pipe drain from bottom of curb to inlet. Aggregate to be placed around inlet end of pipe.
- 5 3" dia. pipe to be kept open for drainage of subgrade or base until surface is placed.

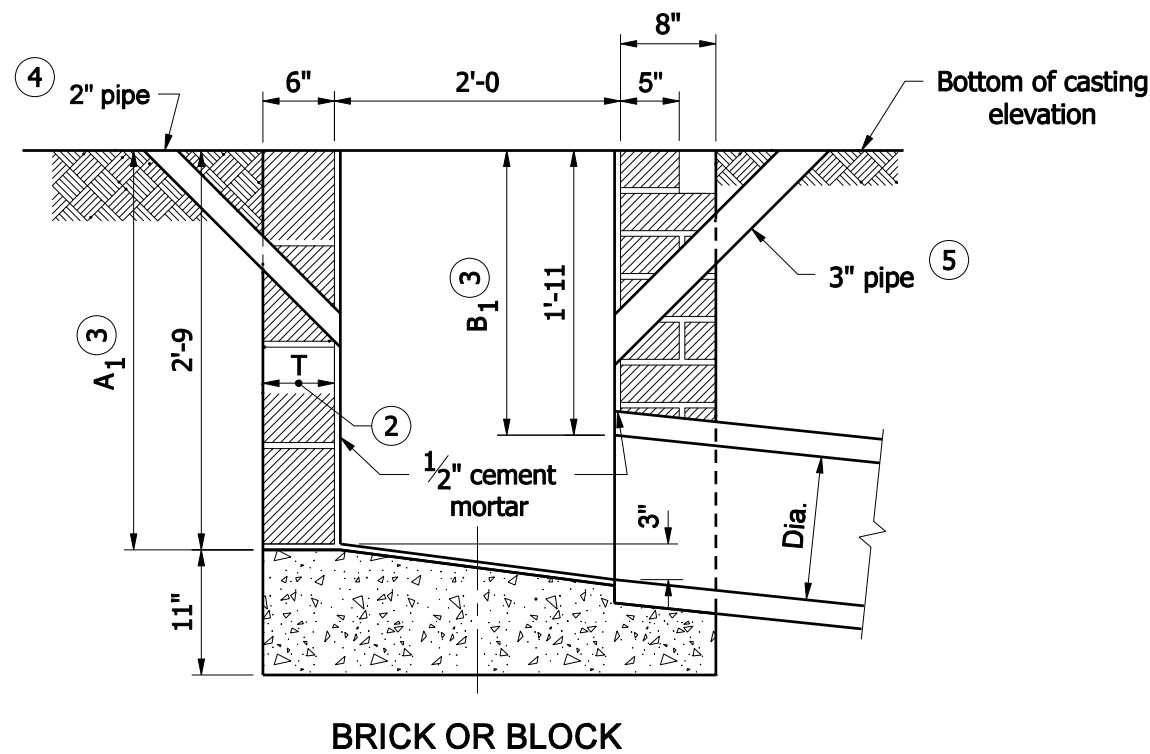
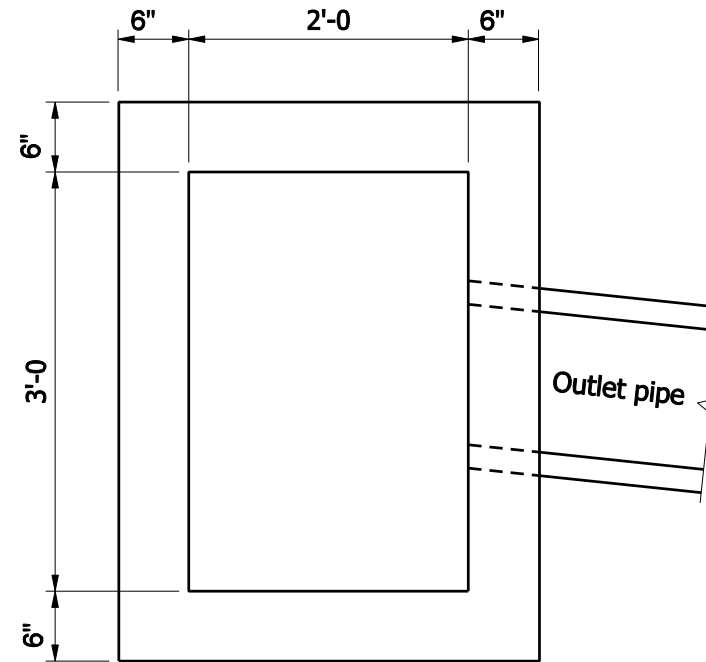
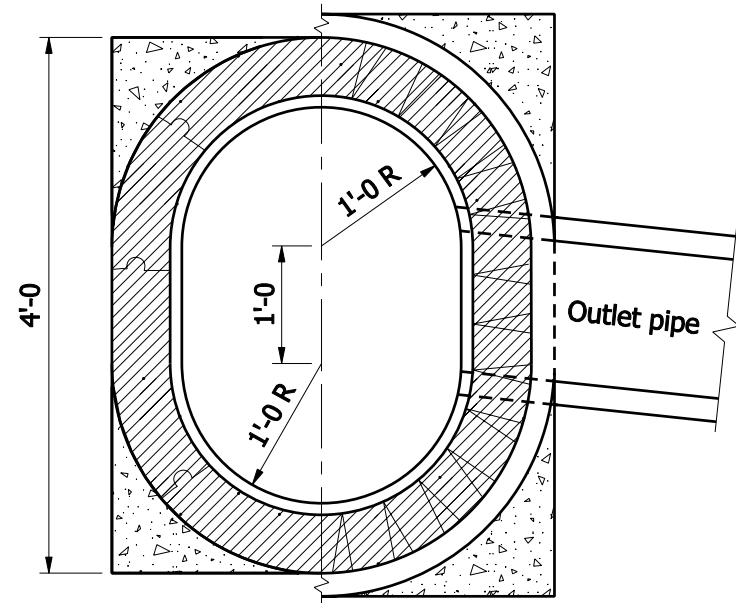

BRICK OR BLOCK

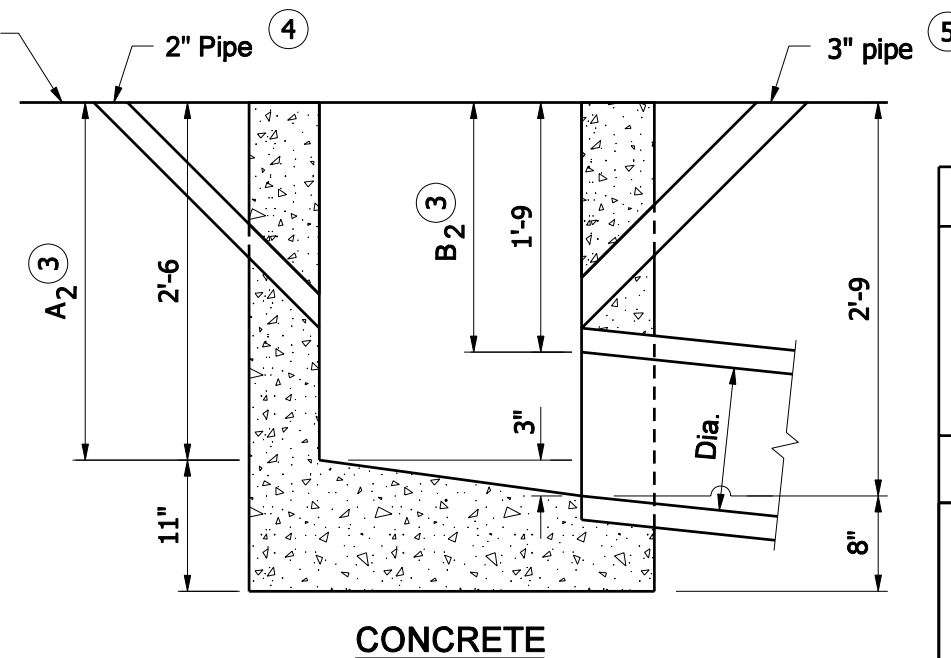

CONCRETE

INDIANA DEPARTMENT OF TRANSPORTATION											
INLET TYPE J											
SEPTEMBER 2008											
STANDARD DRAWING NO. E 720- INST-06											
	<table style="width: 100%; border-collapse: collapse;"> <tr> <td style="text-align: center;"><i>/s/ Richard L. VanCleave</i></td> <td style="text-align: right;">09/02/08</td> </tr> <tr> <td style="text-align: center;">DESIGN STANDARDS ENGINEER</td> <td style="text-align: right;">DATE</td> </tr> <tr> <td colspan="2"> </td> </tr> <tr> <td style="text-align: center;"><i>/s/ Mark A. Miller</i></td> <td style="text-align: right;">09/02/08</td> </tr> <tr> <td style="text-align: center;">CHIEF HIGHWAY ENGINEER</td> <td style="text-align: right;">DATE</td> </tr> </table>	<i>/s/ Richard L. VanCleave</i>	09/02/08	DESIGN STANDARDS ENGINEER	DATE			<i>/s/ Mark A. Miller</i>	09/02/08	CHIEF HIGHWAY ENGINEER	DATE
<i>/s/ Richard L. VanCleave</i>	09/02/08										
DESIGN STANDARDS ENGINEER	DATE										
<i>/s/ Mark A. Miller</i>	09/02/08										
CHIEF HIGHWAY ENGINEER	DATE										
DESIGN STANDARDS ENGINEER											

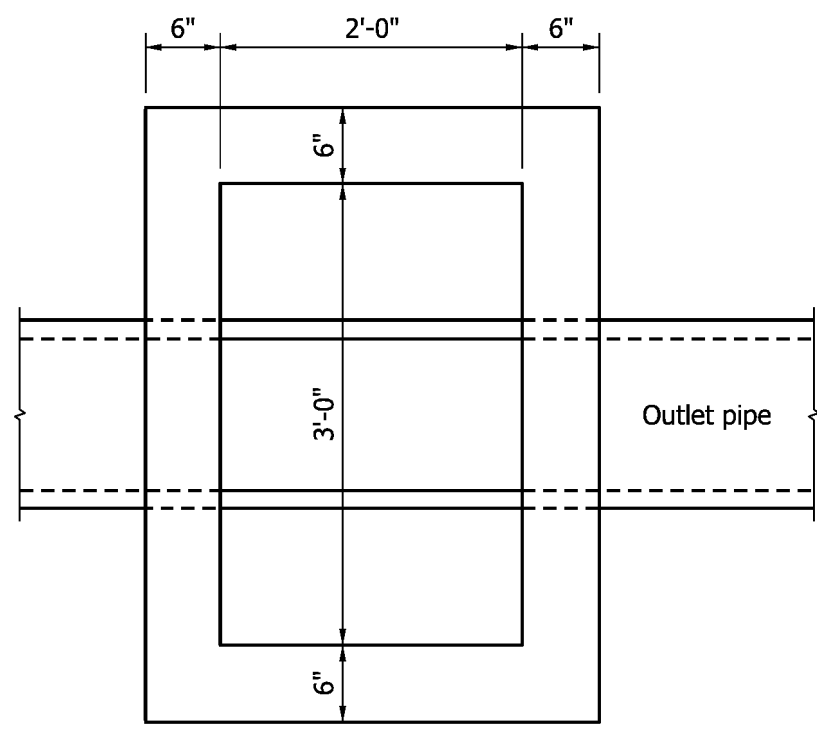

PLAN

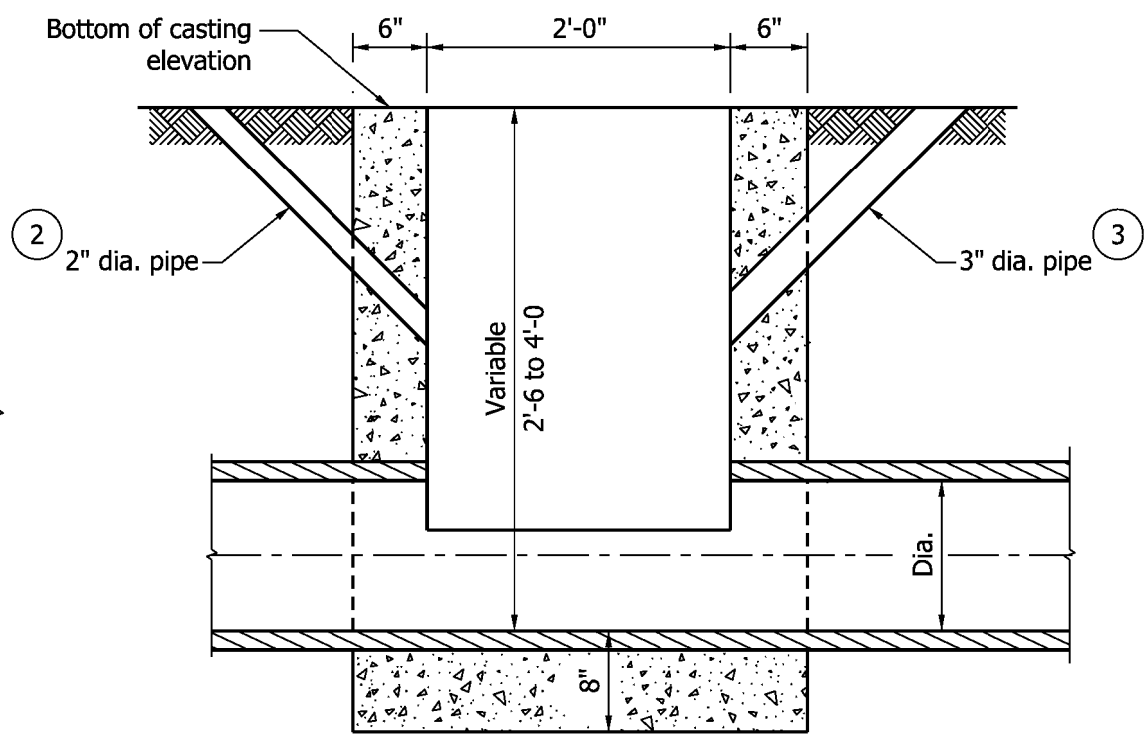

SECTION

INLET TYPE M (CONC)

- GENERAL NOTES**
- 1 If inlet pipe is required, A_1 and B_1 shall be increased or decreased 1'-0 as directed.
 - 2 2" dia. drain from bottom of curb to inlet. Aggregate to be placed around inlet end of pipe.
 - 3 3" min. dia. pipe to be kept open for drainage of subgrade or base until surface is placed.

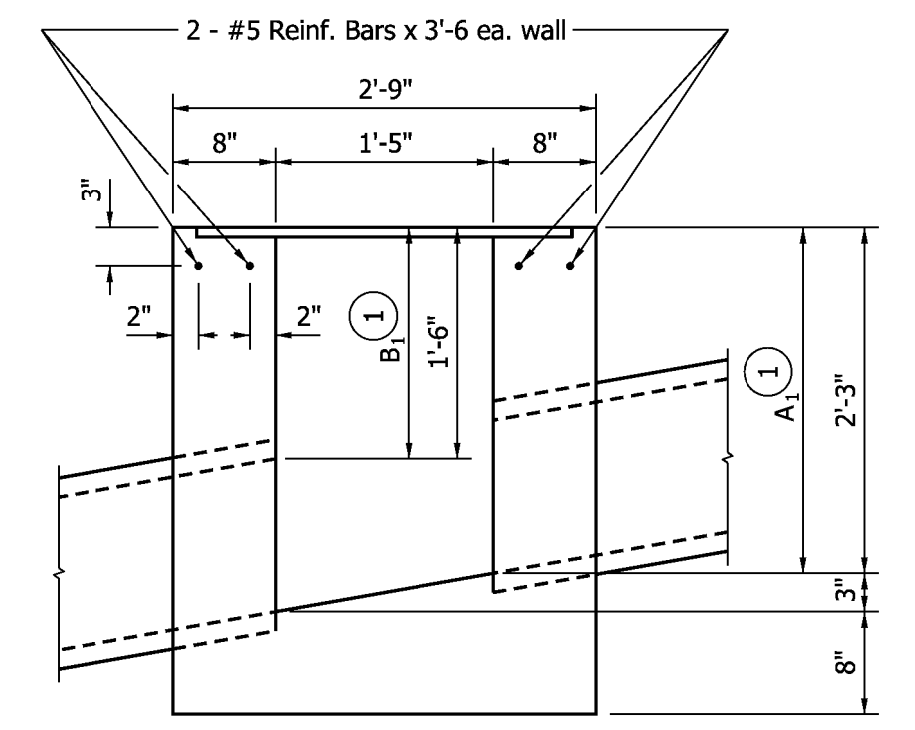

SECTION B-B

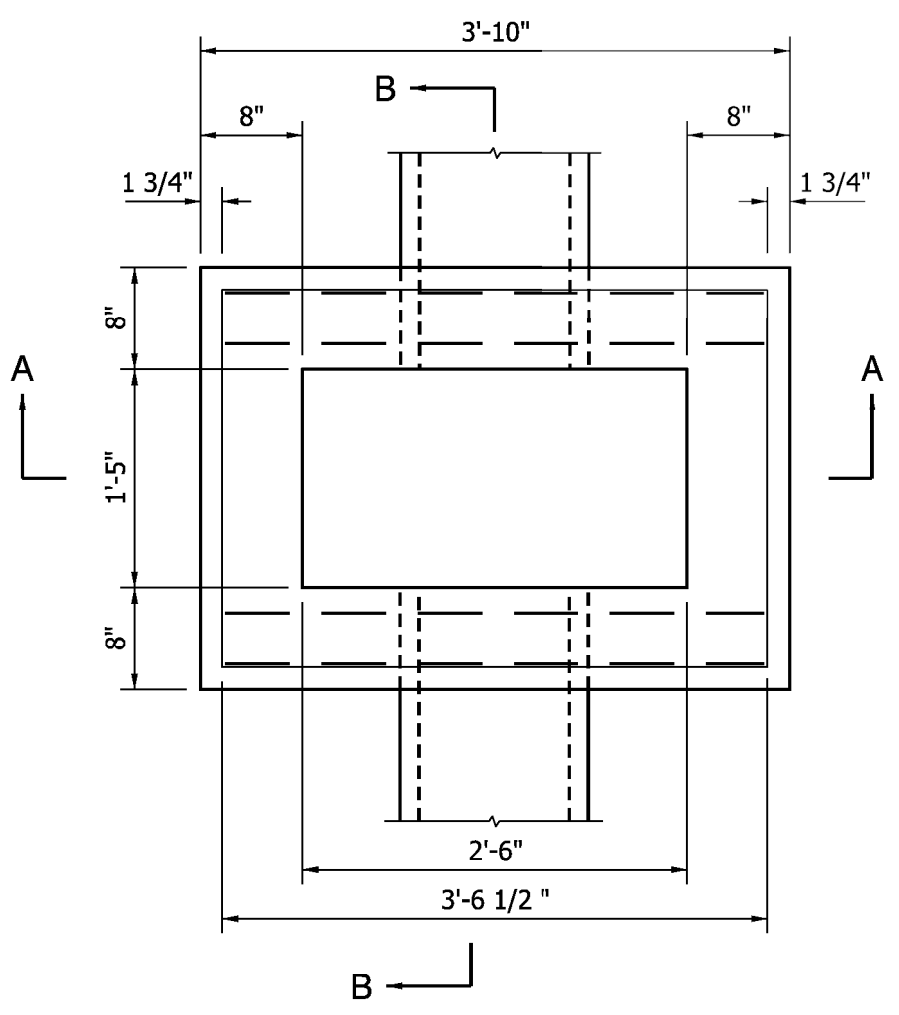

SECTION A-A
INLET TYPE R (Conc.)

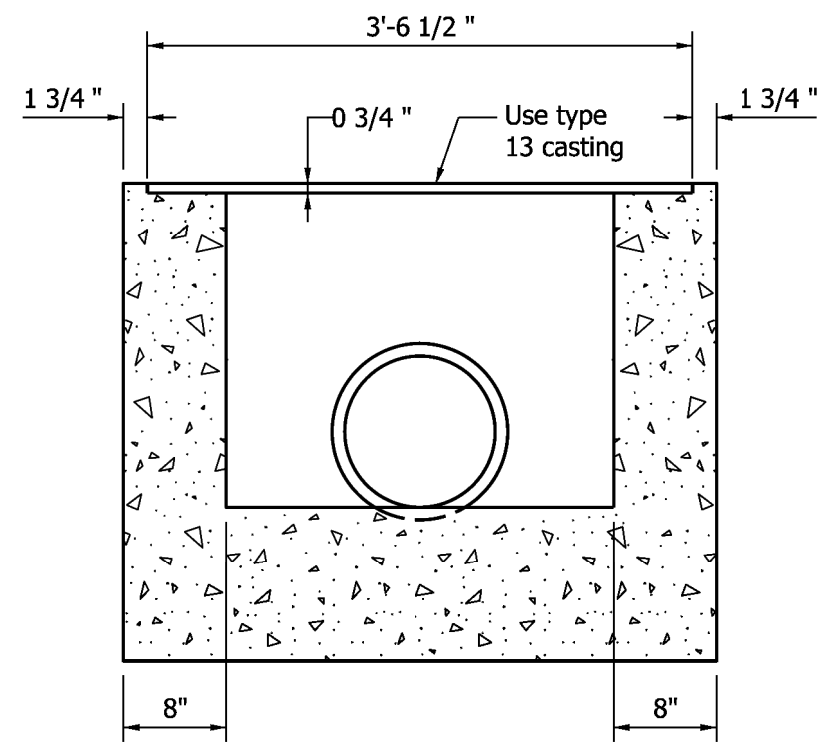

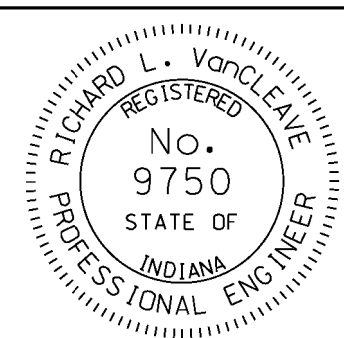
INDIANA DEPARTMENT OF TRANSPORTATION	
INLET TYPE M & R	
SEPTEMBER 2009	
STANDARD DRAWING NO.	E 720 INST-07
	<p><i>/s/ Richard L. VanCleave</i> 09/01/09 DESIGN STANDARDS ENGINEER DATE</p> <p><i>/s/ Mark A. Miller</i> 09/01/09 CHIEF HIGHWAY ENGINEER DATE</p>
DESIGN STANDARDS ENGINEER	

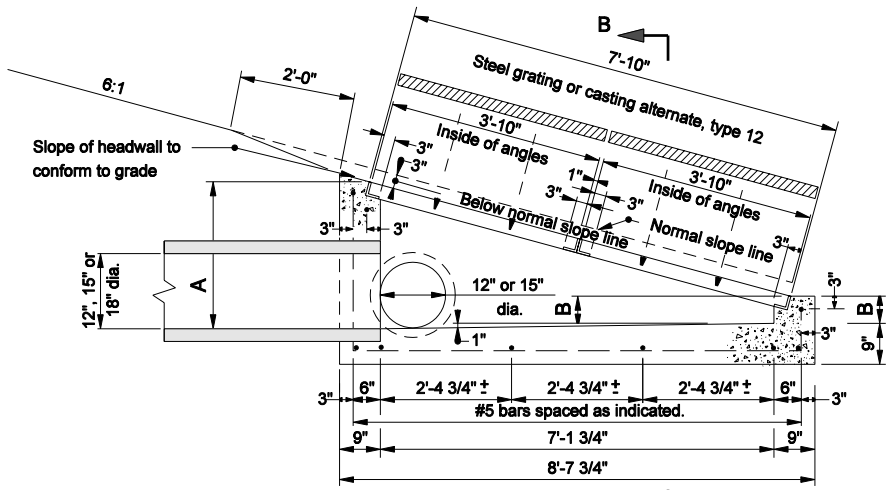

SECTION A-A
Showing Grate Slope of 6:1

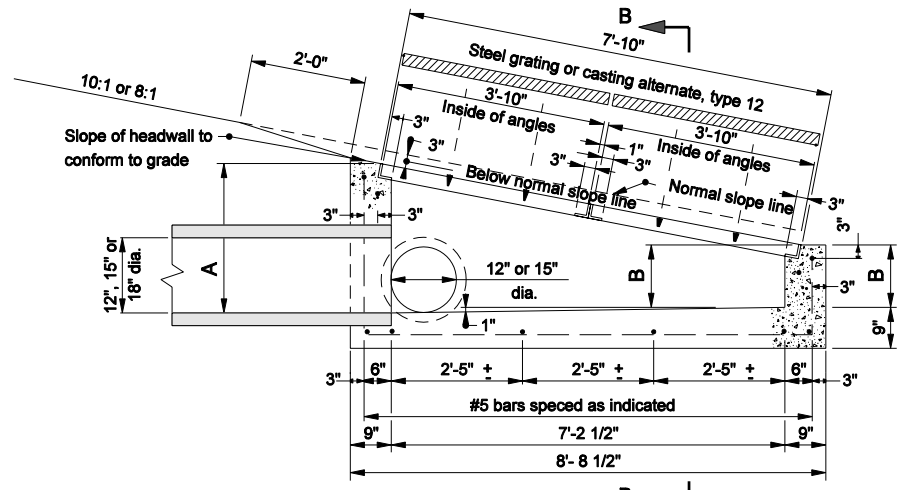

SECTION A-A
Showing Grate Slope of 8:1 or 10:1

TYPE N INLET						
PIPE SIZE	6:1		8:1		10:1	
	A	B	A	B	A	B
12"	21 1/2"	5"	21 1/2"	8 7/8"	21 1/2"	11 1/8"
15"	24 3/4"	8 1/4"	24 3/4"	12 1/8"	24 3/4"	14 3/8"
18"	28"	11 1/2"	28"	15 3/8"	28"	17 5/8"

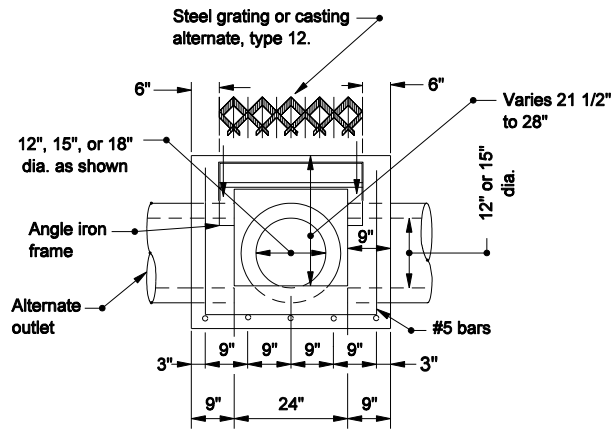

SECTION B-B

INDIANA DEPARTMENT OF TRANSPORTATION

INLET TYPE N

SEPTEMBER 2005

STANDARD DRAWING NO. E 720-INST-08

	/s/ Richard L. VanCleave	9-01-05
	DESIGN STANDARDS ENGINEER	DATE
	/s/ Richard K. Smutzer	9-01-05
DESIGN STANDARDS ENGINEER	CHIEF HIGHWAY ENGINEER	DATE

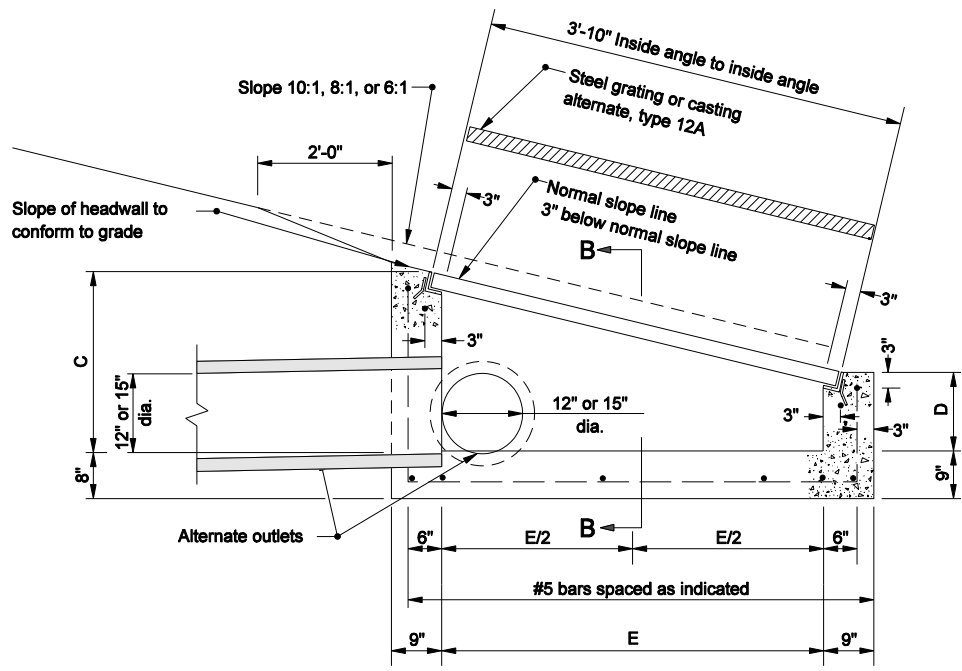

TYPE P INLET

- NOTE:**
- See Standard Drawing E 720-ICCA-10 for steel grating Type 12 or E 720-ICCA-11 for castion Type 12 Alternate.

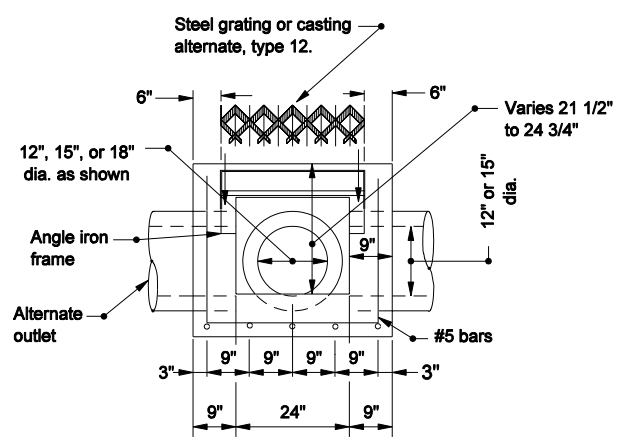

SECTION B-B

TYPE P INLET									
PIPE SIZE	6:1			8:1			10:1		
	C	D	E	C	D	E	C	D	E
12"	21 1/2"	13"	3'-3 1/4"	21 1/2"	14 1/2"	3'-3 3/4"	21 1/2"	15 7/8"	3'-3 3/4"
15"	24 3/4"	16 1/4"	3'-3 1/4"	24 3/4"	18"	3'-3 3/4"	24 3/4"	19 1/8"	3'-3 3/4"

INDIANA DEPARTMENT OF TRANSPORTATION

INLET TYPE P

SEPTEMBER 2005

STANDARD DRAWING NO. E 720-INST-09

	/s/ Richard L. VanCleave	9-01-05
	DESIGN STANDARDS ENGINEER	DATE
	/s/ Richard K. Smutzer	9-01-05
	CHIEF HIGHWAY ENGINEER	DATE

DESIGN STANDARDS ENGINEER

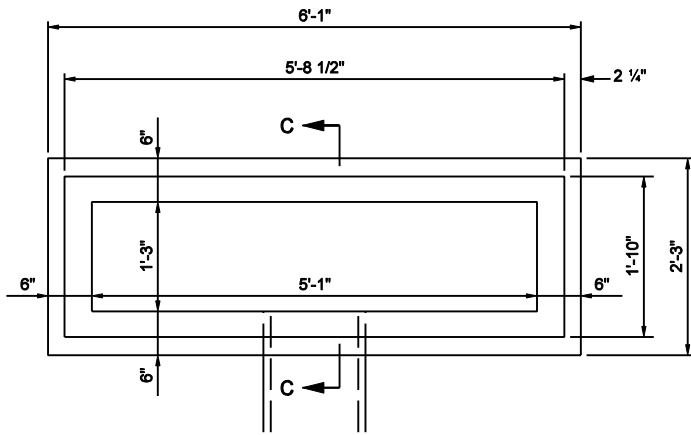

PLAN

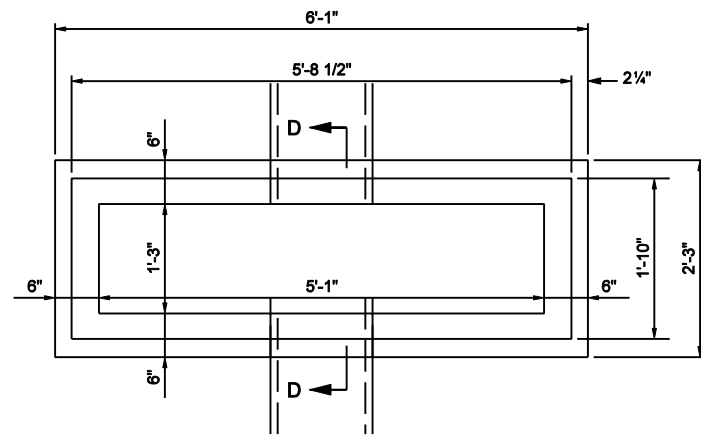

PLAN

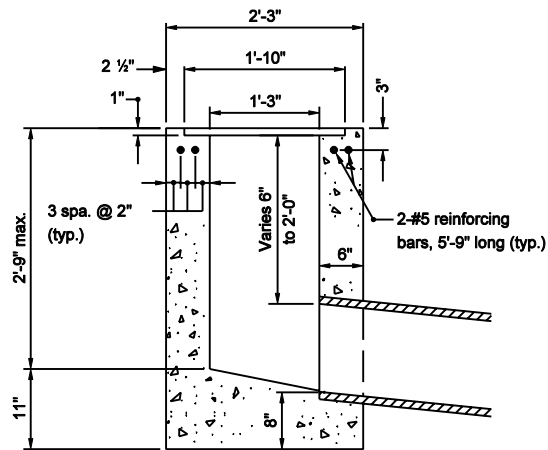

SECTION C-C

TYPE S

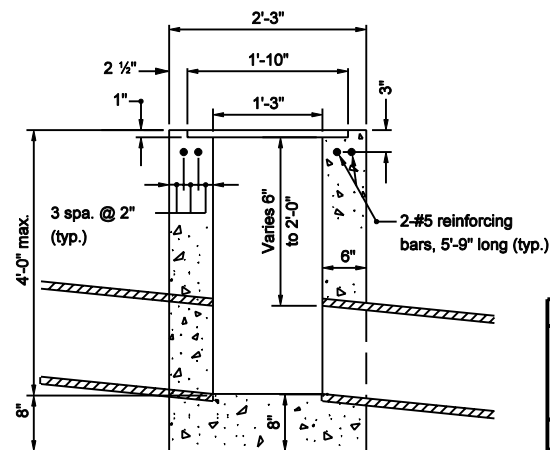

SECTION D-D

TYPE T

INDIANA DEPARTMENT OF TRANSPORTATION

INLETS TYPE S AND T

SEPTEMBER 2003

STANDARD DRAWING NO. E 720-INST-10

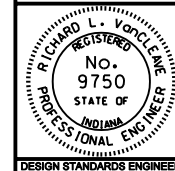

/s/ Richard L. VanCleave 9-02-03
DESIGN STANDARDS ENGINEER DATE

/s/ Richard K. Smutzer 9-02-03
CHIEF HIGHWAY ENGINEER DATE

DESIGN STANDARDS ENGINEER